

SUNRISE UNIVERSAL CREDIT BOARD Mk4A.

Standard pricing, Australia / N.Z.

Feb 2009

Part no **STD162/NRI** Universal Credit Board Mk4A allows the NRI and other electronic or mechanical coin mechs to be used for all of the following applications.

Part no **STD164/NRI** Universal Video Credit Board Mk4A may be used for any of the Video Game applications.

APPLICATIONS

1.Video Game: Standard Mode.

Standard "conversion" Video game with one or two coin mechs operating together, with a single credit output connection to the game PCB.

2.Video Game: Separate Mech Mode.

For 2 player video games designed to operate with separate coin entry for each player (e.g. some Neo-Geo). The Left and Right player coin mechs operate independently, with a Left and Right credit output. Effectively, this mode provides two credit boards in one.

3. Video Game: Stored Credit, 4 Players.

For 2, 3 or 4 player games designed to operate with separate coin entry for each player. The credit board allows 1 or 2 multi-coin mechs, the credit board stores incoming credit. Each player presses his button to take credit from credit pool. Allows multi player games to operate from a single coin mech. Optional coin / credit display panel.

4. Video Game: 2 Channel Credit Board Mk2.

Exact emulation of the superseded "2 Channel Credit Board Mk2". This mode is provided for compatibility and only for use as a service replacement.

5. Skilltester.

Allows connection of 1 or 2 multi-coin accepters to the 20 cent Skill tester models, with optional coin / credit display panel. Can also be used with other games which require coin lockout handshaking, or relay isolated credit output.

6. Pinball.

The isolated relay output allows connection of 1 or 2 multi-coin accepters to switch matrix operated games such as Williams Pinball.

COMMON FEATURES

L COIN & R COIN CONNECTORS. The 10 pin box headers may be connected to one or two QL, NRI, or C120 coin mechanisms. Channel 1 = 50c, chan 2 = 10c, chan 3 = 20c, chan 4 = \$1, chan 5 = \$2 and chan 6 disabled or 1 token / 1 credit operation. Alternatively, coin switches may connect to the designated edge connector pins.

INDIRECT CREDIT CONVERSION. (Preferred operating mode). Bonus credits calculated on the total value of coins inserted, regardless of individual denomination. *Example:- If 1 x Two Dollar coin gives 3 credits, then so will 2 x One Dollar coins.*

or **DIRECT CREDIT CONVERSION.** Coin denominations may not be mixed. (Indirect credit conversion is generally preferred).

ANTENNA. A simple static pickup antenna wire may be connected to the credit board. The length of the wire and its proximity to the cabinet wiring harness will determine the sensitivity of the static reset function. Operation is indicated by the on-board LED indicator.

SPARK RESET OUT. This is an open collector, active low output which may be connected to the game board RESET input. If the game board has no reset input, a PCB technician could add the input to the game board, via an unused edge connector pin.

COIN METER. All coin registrations are accumulated as 10 cent units on a single coin meter. Connect coin meter between 12 volts and Coin Meter Output. No diode is needed, the credit board contains an internal protection diode.

LAMP OUTPUT. This output allows installation, where appropriate, of 12 volt lamps inside lit Start Buttons.

ALARM Anti Stringing Alarm. Triggered if coin switch closed longer than 250 mS. This open collector output may be connected to a general purpose Piezo Screamer, (-) lead to credit board, (+) lead to +12 volt supply. Alternatively it may be connected to a game board RESET input, so that stringing causes game to immediately reset, and stay reset for 10 seconds.

DISPLAY DATA, CLOCK. Where appropriate, the separately sold 6 digit or 2 digit LED display PCB may be connected. The 6 digit display shows \$-c inserted and the resulting credit. The 2 digit display shows credit only.

SERVICE CREDIT SWITCH input, allows a push button switch to give free credits for testing the game without incrementing coin meter. Also allows Free Game Mode.

FREE GAME MODE. This mode is entered by holding the SERVICE CREDIT switch closed for four seconds or longer. If fitted, the start button lamps light and remain lit. The credit display shows 99. Pressing a start button will then start a free game, or a two player start button will start a two player game. The Free Game Mode remains in operation until the host game is switched off.

DIP SWITCH SETTINGS

N = on, F = off

DIP SW 12345678	1st credit, bonus credit	DIP SW 12345678	1st credit, bonus credit
-FFFFF-	10c=1	-NFFFNN-	\$1=1, \$2=4
-NFFFF-	20c=1	-FFFNNN-	\$1=1, \$4=6
-FNFFFF-	20c=1, 40c=3	-NNNFNN-	\$1=1, \$5=6
-NNFFFF-	20c=1, \$1=6	-FFFNNF-	\$2=1
-FFNFFF-	20c=1, \$1=7	-NFFNFF-	\$2=1, \$3=2
-NFNFFF-	40c=1	-FNNNNF-	\$2=1, \$3=2, \$4=4
-FNNFFF-	40c=1, 60c=2, 80c=3, \$1=4	-FNFNFF-	\$2=1, \$3=2, \$5=4
-NNNFFF-	40c=1, \$1=3 (\$2=6)	-NFFNFF-	\$2=1, \$4=3
-FFNFFF-	40c=1, \$1=3, \$2=7	-FNNNNF-	\$2=1, \$4=3, \$5=5
-FFNFNF-	40c=1, \$1=3, \$2=8	-NFNNNF-	\$3=1
-NFFNFN-	40c=1, \$1=3, \$2=9	-FNFFNN-	\$3=1, \$5=2, \$7=3
-FNFNFN-	40c=1, \$1=4 (\$2=8)	-NNNNNF-	\$3=1, \$5=2, \$10=5
-NNNFNF-	40c=1, \$1=4, \$2=9	-FFFFFN-	\$3=1, \$5=2, \$8=4, \$10=6
-FFNNFN-	40c=1, \$1=4, \$2=10	-NFFFFN-	\$4=1
-NFFNFF-	50c=1 (\$1=2, \$2=4)	-NNFFFN-	\$4=1, \$8=3, \$12=5
-FNNNFN-	50c=1, (\$1=2), \$2=5	-NFNFNN-	\$4=1, \$6=2
-NNNNFN-	50c=1, \$1=3 (\$2=6)	-FNNFNN-	\$4=1, \$6=2, \$8=3
-FFFFFN-	50c=1, \$1=3, \$2=7	-FNFNFN-	\$4=1, \$7=2, \$9=3
-FNFFNF-	60c=1	-FNFFFN-	\$4=1, \$10=3
-NFFNFF-	60c=1, \$1=2 (\$2=4)	-NFFFNN-	\$4=1, \$7=2, \$10=3
-FNNFFF-	60c=1, \$1=2, \$2=5	-FNFFFN-	\$5=1
-NNNFFF-	60c=1, \$1=2, \$3=7, \$4=10	-NFNFFN-	\$5=1, \$8=2
-FFNFFF-	80c=1	-FNNFFN-	\$5=1, \$10=3
-NFFNFF-	80c=1, \$2=3	-NNNFFN-	\$5=1, \$10=3, \$15=5
-FNFNFF-	80c=1, \$2=3, \$5=8	-FNFNFN-	\$6=1, \$8=2
-NFFNFF-	\$1=1, (\$2=2)	-NNFNFN-	\$7=1
-FNFFNF-	\$1=1, \$2=3	-FFNNNN-	\$8=1
-NNFFNF-	\$1=1, \$2=3, \$3=5	-NFNNNN-	\$9=1
-FFNFNF-	\$1=1, \$2=3, \$5=8	-FNNNNN-	\$10=1
-NFNFNF-	\$1=1, \$2=3, \$4=7		
-FNNNFN-	\$1=1, \$2=3, \$4=7, \$5=10		
-NNNFNF-	\$1=1, (\$2=2) \$3=4		

OPERATING MODES

N-----F	1.Video Game: Standard	F-----F	5.Skilltester
N-----F	2.Video Game: Separate	N-----F	6.Pinball
N-----N	3.Video Game: 4 Player	NNNNNNNN	Display Test
F-----N	4.Video Gamw: 2 Channel Mk2		

Adjust game PCB for 1 coin / 1 credit.

CONNECTION DETAILS

(1). VIDEO GAME : STANDARD

EDGE CONNECTOR

Component Side	Solder Side	
	1 Player 1 Start input	
	2 Player 2 Start input	
10c. input RIGHT	3 Service credit switch input	INDIRECT CREDIT CONVERSION (Preferred)
20c. coin input R	4 10c coin input LEFT	1. BONUS RESET by START BUTTON. Pins 1s & 2s should be connected to the cabinet Start Switch buttons, which also connect to the Game Board. If the game uses only one Start Switch, Player 2 Start is not connected.
50c. coin input R	5 20c coin input L	
\$1 coin input R	6 50c coin input L	
\$2 coin input R	7 \$1 coin input L	
Antenna	8 \$2 coin input L	
Free Game Lamp	9 -	
	10 -	or:-
Spark Reset out	11 Alarm output	2. BONUS RESET by 30 Second TIMER. Do not connect Start Buttons to credit board. Connect Pin 1s permanently to Ground. Bonus system will reset 30 seconds after insertion of the last coin.
	12 Coin Meter output	
	13 Credit output to Game Board	COIN ENABLE INPUT. To GND or external control.
	14 -	
	15 -	
Coin Enable input	16 -	
	17 -	
	18 -	DIRECT CREDIT CONVERSION (Indirect conversion normally preferred). Do not connect Start Buttons to credit board. Instead, connect pin 13s (output) to pin 1s (player 1 input), in addition to game board coin input.
12 volts DC	19 Power input, 12 volts DC	
" "	" " " " "	
" "	" " " " "	
Ground	21 Ground	
" "	22 " "	

Free game lamp driver is provided for use in Free Game Mode. (See "APPLICATIONS", page 1).

(2). VIDEO GAME: Separate Mech Mode

EDGE CONNECTOR

COMP SIDE	SOLDER SIDE
Twin Mode sel.(GND)	1 Left Player Start Switch
Right Service Sw	2 Right Player Start Switch
R coin 10c.	3 Left Service Switch
R coin 20c.	4 L coin 10c.
R coin 50c.	5 L coin 20c.
R coin \$1.	6 L coin 50c.
R coin \$2.	7 L coin \$1.
Antenna	8 L coin \$2.
Credit Lamp Output	9 -
-	10 -
Spark Reset out	11 Alarm output
-	12 Coin Meter output, 10c.
R Credit Output	13 L Credit Output
-	14 -
-	15 -
Coin Enable Input	16 -
-	17 -
-	18 -
12 volts DC	19 Power input, 12 volts DC
" "	20 " " " "
Ground	21 Ground
" "	22 " "

INDIRECT CREDIT CONVERSION (Preferred operating mode).

1. BONUS RESET by START BUTTON. Pins **1s** & **2s** should be connected to the cabinet Start Switch buttons, which also connect to the Game Board. This connection also required if Free game Mode is used.

or:-

2. BONUS RESET by 30 Second TIMER. Do not connect Start Buttons to credit board. Connect Pin **1s** permanently to Ground. Bonus system will reset 30 seconds after insertion of the last coin.

COIN ENABLE INPUT. To GND or external control.

DIRECT CREDIT CONVERSION (Indirect conversion normally preferred). Do not connect Start Buttons to credit board. Instead, connect pin **13s** (L output) to pin **1s** (L Start), and pin **13c** (R output) to pin **2s** (R Start), in addition to their connections to the game board coin inputs.

(3). VIDEO GAME: Stored Credit, 4 Players

EDGE CONNECTOR

COMP SIDE	SOLDER SIDE
P3 Credit switch	1 P1 Credit switch
P4 Credit switch	2 P2 Credit switch
R coin 10c.	3 Service Switch
R coin 20c.	4 L coin 10c.
R coin 50c.	5 L coin 20c.
R coin \$1.	6 L coin 50c.
R coin \$2.	7 L coin \$1.
Spark Antenna	8 L coin \$2.
Credit Lamp output	9 -
-	10 -
Spark Reset Out	11 Alarm output
-	12 Coin Meter output
P2 Credit Out	13 P1 Credit Out
P3 Credit Out	14 Display Panel DATA
P4 Credit Out	15 Display panel CLOCK
Coin Enable Input	16 -
-	17 -
-	18 -
Power input, 12 volts	19 Power input, 12 volts
" " " "	20 " " " "
Ground	21 Ground
" "	22 " "

OPERATION.

After credit is gained, LAMP flashes, DISPLAY shows total value of coins in \$-c and the current credit.

Each press of a player Credit button sends one credit to that player's Credit Output. Lamp stops flashing and remains lit until all credit has been taken.

COIN ENABLE INPUT. To GND or external control.

(4). VIDEO GAME: 2 Channel Credit Board Mk2 Emulation

EDGE CONNECTOR

COMP SIDE	SOLDER SIDE
	1 Player 1 "Take credit" switch
	2 -
	3 Service credit switch input
	4 10c coin switch input
	5 20c coin switch input
	6 Player 2 "Take credit" switch
	7 \$1 coin switch input
Antenna	8 \$2 coin switch input
	9 -
	10 -
Reset Out	11 Credit Lamp driver output
	12 Coin Meter output
Credit Out Plr.2	13 Credit output Player 1
	14 Display Panel DATA
	15 Display panel CLOCK
	16 -
	17 -
	18 -
	19 Power input, 12 volts DC
	20 " " " "
Ground	21 Ground
" "	22 " "

NOTES:-

Directly substitutes for Multi Credit Mk2 "2 Channel Credit Board" in existing installations. *For new installations, follow "Stored Credit, 4 Players" installation instructions, and leave 3rd and 4th player functions un-connected.*

(5). SKILLTESTER

Requires Universal Credit Board part no STD162/NRI

EDGE CONNECTOR PINOUT

<u>Component Side</u>	<u>Solder Side</u>
	1 Move Forward button (S.T. pin 4)
	2 -
R coin 10c.	3 Service Switch
R coin 20c.	4 L coin 10c.
R coin 50c.	5 L coin 20c.
R coin \$1.	6 L coin 50c.
R coin \$2.	7 L coin \$1.
Spark Antenna	8 L coin \$2.
	9 +12 volts DC
	10 Lockout sense (S.T. pin 11)
	11 Alarm output
	12 Coin Meter output
	13 -
	14 Display Panel DATA
	15 Display panel CLOCK
-	16 Credit out COM. (S.T. pin 12)
	17 -
	18 Credit out N.O. (S.T. pin 8)
12 volts DC	19 Power input, 12 volts DC
" "	20 " " " "
Ground	21 Ground
" "	22 "

BONUS RESET by START BUTTON. Pin 1, solder side should be connected as shown to the Move Forward button input of the Skilltester Game Board, pin 4.

BONUS RESET by 30 Second TIMER. Connect credit board Pin 1s permanently to Ground, instead of to Move Forward button. Bonus system will reset 30 seconds after the insertion of the last coin.

ALARM Anti Stringing Alarm. This open collector output may be connected to a general purpose Piezo Screamer, (-) lead to pin 11, (+) lead to +12 volt supply.

(6). PINBALL.

Requires Universal Credit Board part no STD162/NRI

EDGE CONNECTOR

<u>Component Side</u>	<u>Solder Side</u>
-	1 Connect to Ground
-	2 -
10c. input RIGHT	3 Service credit switch input
20c. coin input R	4 10c coin input LEFT
50c. coin input R	5 20c coin input L
\$1 coin input R	6 50c coin input L
\$2 coin input R	7 \$1 coin input L
Spark Antenna	8 \$2 coin input L
-	9 -
-	10 -
-	11 Alarm output
-	12 Coin Meter output
-	13 -
-	14 -
-	15 -
-	16 RELAY OUTPUT common
-	17 RELAY OUTPUT normal closed
-	18 RELAY OUTPUT normal open
12 volts DC	19 Power input, 12 volts DC
" "	20 " " " "
Ground	21 Ground
" "	22 "

Instructions are given for a Williams Pinball. Other games requiring an isolated connection to a switch matrix type coin input can use a similar connection.

Adjust the pinball pricing **1 coin 1 game**. Set the credit board for the desired coins/game and bonus.

Credit board bonus coin system resets automatically 30 seconds after insertion of the last coin.

Power. In a Williams pinball, 12 V DC unregulated is obtained from the power supply PCB connector **3P6 pin 6** (grey/white wire). GND is connected to **3P6 pin 11** (black wire).

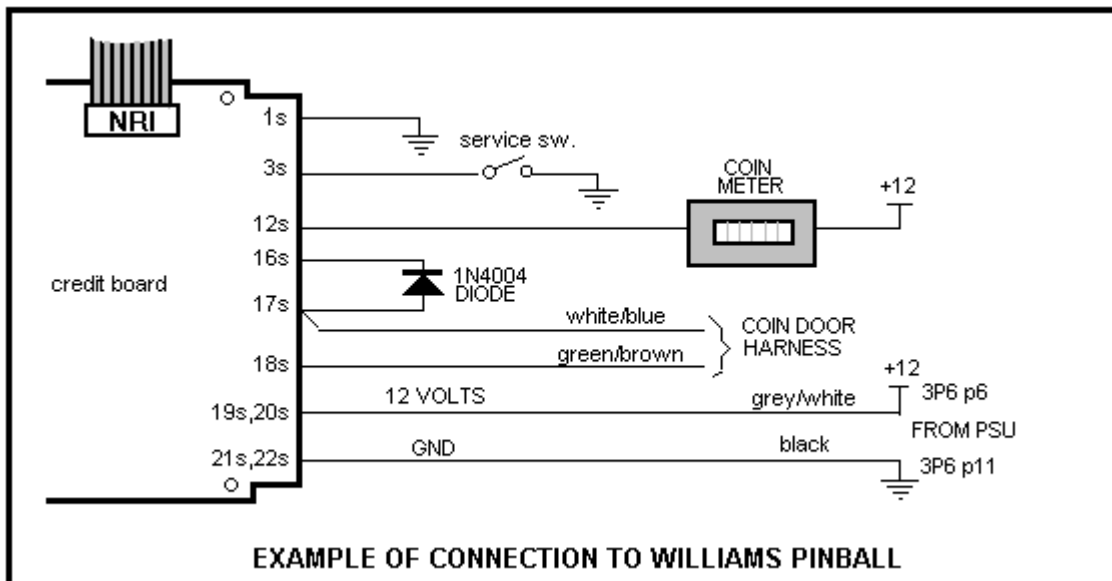

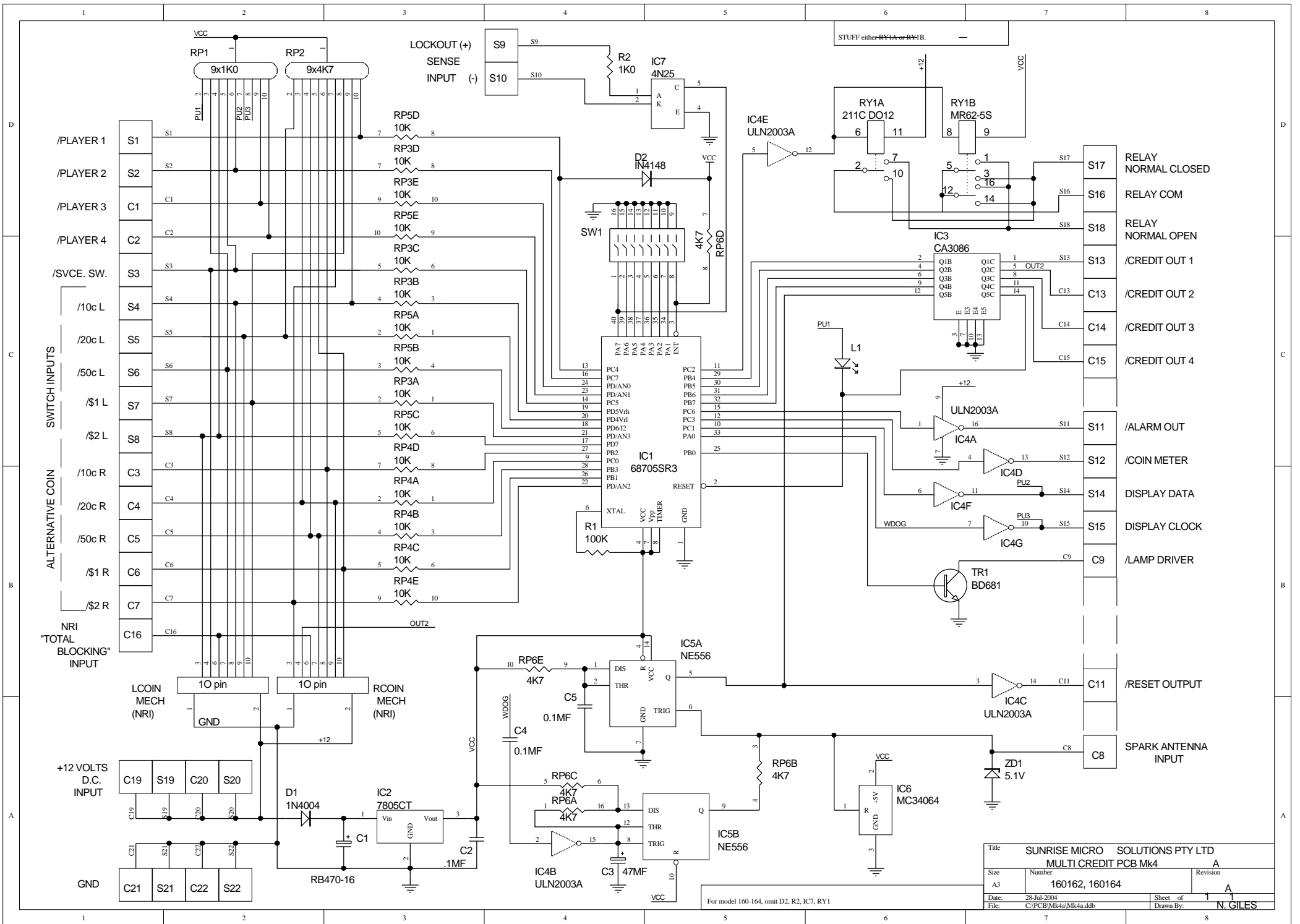

Title			SUNRISE MICRO SOLUTIONS PTY LTD		
Size			MULTI CREDIT PCB Mk4		
Number			A		
Revision			1		
Date:			28-Jul-2004		
File:			C:\PCB\Mk4a\Mk4a.ddb		
Sheet of			1		
Drawn By:			N. GILES		

For model 160-164, omit D2, R2, IC7, RY1